

TXC7002/TXC7004/TXC7008/TXC7016
Conventional Fire Alarm Control Panel
Installation and Operation Manual



TANDA DEVELOPMENT PTE. LTD. Copyright ©2025, All right reserved.

Product Safety

To prevent severe injury and loss of life or property, read the instruction carefully before installing the Control Panel to ensure proper and safe operation of the system.



European Union directive

2012/19/EU (WEEE directive): Products marked with this symbol cannot be disposed of as unsorted municipal waste in the European Union. For proper recycling, return this product to your local supplier upon the purchase of equivalent new equipment, or dispose of it at designated collection points.

For more information please visit the website at www.recyclethis.info

Disclaimer

The information in this manual is furnished for informational use only and subject to the change without notice. While every effort has been made to ensure that the information contained in this user manual is accurate, reliable and up to date. The TANDA Technology cannot be held responsible for inaccuracies or error that may appear in this manual.

Contents

1 Overview	5
1.1 Features	5
1.2 Technical Specifications	5
1.3 Controls and Indications	7
1.3.1 Common Status Indicators	7
1.3.2 Zone Status Indicators	8
1.3.3 Operating Indicators and Keys	8
1.4 Configuration and Functions	9
1.4.1 Internal Components	9
1.4.2 Configuration and functions of TXC7016	9
1.4.3 Configuration and Functions of TXC7008	10
1.4.4 Configuration and Functions of TXC7004	10
1.4.5 Configuration and Functions of TXC7002	10
1.5 Terminal Description	10
1.5.1 Power input terminals on Power Board and control board	10
1.5.2 Terminals on Control Board of TXC7002	10
1.5.3 Terminals on Control Board of TXC7004	11
1.5.4 Terminals on Control Board of TXC7008 and TXC7016	12
1.5.5 Terminals on Extension Board of TXC7016	12
1.5.6 Terminals on Relay Board of TXC7016 (optional)	13
1.5.7 Terminals on Relay Board of TXC7002/TXC7004/TXC7008 (optional)	13
1.6 Overall Dimensions	13
2 Installation and Wiring	14
2.1 Installing the Cabinet	14
2.2 Mains Connection	14
2.3 Battery Connection	14
2.4 Zone Inputs Connection	15
2.5 Sounder Outputs Connection	15
3 System Setup	16
3.1 Setting Access Levels	16
3.2 Setting Alarm/ Sounder 1# Output	16
3.3 Setting Disablement Function	17
3.4 Setting Test Mode (For future use)	17
3.5 Programming Output Mode (For future use)	18
3.6 Setting Supervisory (For future use)	20
3.7 Setting Auxiliary Functions (For future use)	21
3.8 Ground Fault Detection	21
3.9 Setting Auxiliary Power	21
3.10 Restore Default Settings (For future use)	21
4.1 Working State Description	22
4.2 Muting of Buzzer	23
4.3 Silencing the Sounder Outputs	23
4.4 Evacuation	23
4.5 Self-test and Reset	23
5 Calculation of Batteries Capacity	24
6 Installation Precautions	24
7 Servicing	24
7.1 Replacing the Batteries	24
7.2 Replacing the Fuse	25

EN 54 Information

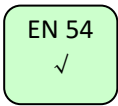

✧ TXC7002/TXC7004/TXC7008/TXC7016 Conventional Fire Alarm Control Panel complies with the requirements of EN 54-2 and EN 54-4. In addition to the basic requirements of these standards, the panel conforms to the following optional requirements.

Option		EN 54-2 Clause
Control	Delays to outputs	7.11
	Test condition	10
Outputs	Output to fire alarm devices	7.8
	Output to fire alarm routing equipment	7.9.1

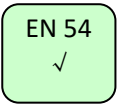

✧ The power supply of the FACP complies with the following EN 54-4 requirements.

Power Supply Functions	EN 54-4 Clause
Power supply from the main power source	5.1
Power supply from the standby power source (batteries)	5.2
Charger	5.3
Faults	5.4

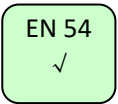

✧ CPD Conformity Information

1 Overview

TXC7002/TXC7004/TXC7008/TXC7016 Conventional Fire Alarm Control Panel is designed in compliance with EN 54-2 and EN 54-4. It's compatible with TXC7101 Conventional Smoke Detector by EN 54-7, TXC7111 Conventional Heat Detector by EN 54-5, TXC7141 Conventional Manual Call Point by EN 54-11 and TXC7301 Conventional Sounder Strobe designed by EN 54-3.

Control functions of the panel are enabled by a key switch and programming functions are enabled by an internal switch. This series of panels are basically the same in application and operation, their differences are zones and sounder outputs. TXC7016 Conventional Fire Alarm Control Panel (called FACP for short) will be described as the example in the following sections.

1.1 Features

- ✧ Up to 16 zones can be detected, compatible with conventional detectors and manual call points. Each of the 16 zones can be individually configured as maximum 15 conventional detectors. The total number of detectors and manual call points in a zone shall not exceed 32.
- ✧ Three sounder outputs, one alarm output, one fault output and one disable/supervisory output.
- ✧ Able to report short and open circuits of zones, sounder outputs and alarm output.
- ✧ Test and disable functions.
- ✧ Programmable on manual call point connection, sound modes, sounder delay modes and output delay modes.
- ✧ Three access levels settable via the key switch and the internal switch.
- ✧ Providing external ports includes *RESET*, *EVAC*, *SILENCE*.
- ✧ Designed with standby batteries and space provision for two sealed lead-acid batteries.

1.2 Technical Specifications

1.2.1 Operating Voltage

- ✧ Input Voltage: 100V~230VAC^{+10%}_{-15%}, 50/60Hz
- ✧ Input Current: 1.2 A
- ✧ Fuse: 250VAC, T2A in SPS
- ✧ Recommended Wiring: 1.5mm² or above shield cable, complying with local installation codes.

Note: External overcurrent protection device is required and should be installed near the equipment.

1.2.2 Operating Voltage

- ✧ Minimum Operating Voltage: 21.5V
- ✧ Maximum Charging Current: 350mA
- ✧ Maximum Charging Voltage: 27.6V
- ✧ Battery Type: Sealed lead-acid battery
- ✧ Maximum Battery Charging Capacity: 2 batteries, 7Ah/12V.
- ✧ Recommended Battery Manufacturer and Model: Yuasa NP7-12

- ✧ Maximum internal resistance of the batteries: 1Ω
- ✧ Standby current of batteries when fully load: 0.1A
- ✧ Maximum operating current of the batteries: 2.1A

1.2.3 Detection Zone

The FACP provides maximum 16 zones; each can be individually configured with maximum 15 conventional detectors.

- ✧ Output voltage: 18VDC~28VDC
- ✧ Standby current: less than 6mA (connecting with 15 conventional detectors)
- ✧ Alarm current: about 25mA
- ✧ End-of-line-resistor: 4.7kΩ
- ✧ Resistance range for fire alarm: 150Ω~1.5kΩ (normally 510Ω)
- ✧ Recommended wiring: 1.0mm² or above shield cable, complying with local installation codes.
- ✧ Recommended cable length: no longer than 1000m

1.2.4 Output Interface

- ✧ Fault output
 - Type: normally open/close contact output
 - Contact capacity: 1A/24VDC
- ✧ Disable/supervisory output (defaulted disable output)
 - Type: normally open/close contact output
 - Contact capacity: 1A/24VDC
- ✧ Alarm output
 - Type: voltage output, normally open/close contact output are available (defaulted voltage output)
 - Contact capacity: 1A/24VDC
 - Output voltage: 18VDC~28VDC
 - Output current: 300mA in alarm
 - End-of-line-resistor: 4.7kΩ
- ✧ Sounder 1# output
 - Type: voltage output, normally open/close contact output (defaulted voltage output)
 - Contact capacity: 1A/24VDC
 - Output voltage: 18VDC~28VDC
 - Output current: 300mA in alarm
 - End-of-line-resistor: 4.7kΩ
- ✧ Sounder 2#~3# output
 - Type: voltage output
 - Output voltage: 18VDC~28VDC
 - Output current: 300mA in alarm
 - End-of-line-resistor: 4.7kΩ
- ✧ Auxiliary Power Output
 - Output voltage: 18VDC~28VDC
 - Output current: 20mA in standby and maximum 500mA in alarm

- ✧ Recommended wiring: 1.0mm² or above shield cable, complying with local installation codes.
- ✧ Recommended cable length: no longer than 1000m

1.2.5 Input Interface (For future use)

- ✧ RESET/EVAC/SILENCE input
 - Type: normally open contact input
- ✧ Recommended wiring: 1.0mm² or above shield cable, complying with local installation codes.
- ✧ Recommended cable length: no longer than 1000m

1.2.6 Installation and Storage

The FACP is applicable for indoor use below the elevation of 2000m. Overvoltage level is Class II and pollution degree is 2.

- ✧ Installation Environment
 - Temperature: -5°C~50°C
 - Relative humidity: ≤95%, non-condensing
- ✧ Storage Environment:
 - Temperature: -25°C~50°C

Relative humidity≤95%, non-condensing

1.3 Controls and Indications

The front panel of the FACP is shown as in Fig. 1-1.

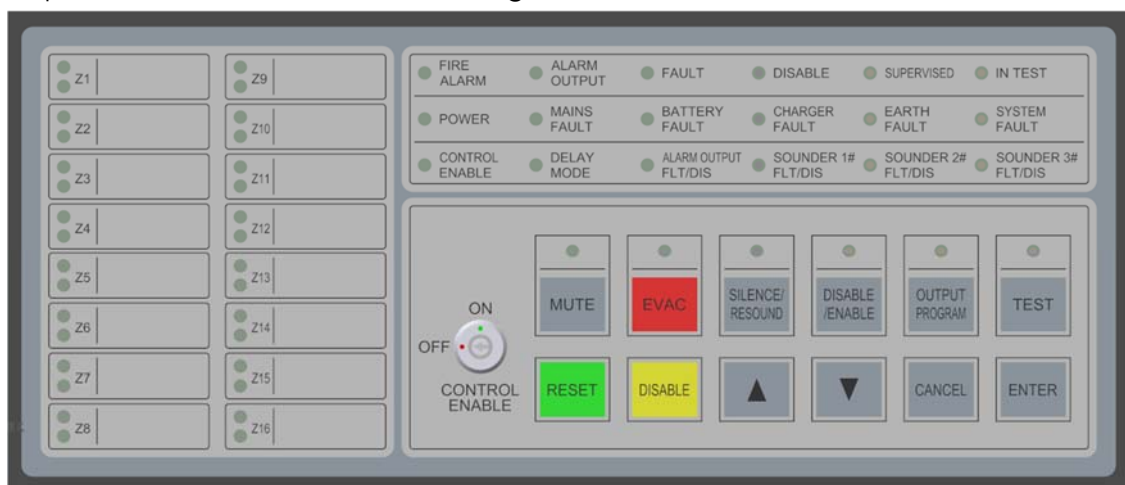

Fig. 1-1

1.3.1 Common Status Indicators

- ✧ **FIRE:** Red. It illuminates steadily when there is a fire alarm.
- ✧ **ALARM OUTPUT:** Red. It illuminates steadily when the alarm output is activated.
- ✧ **FAULT:** Yellow. It illuminates steadily when there is a fault.
- ✧ **DISABLE:** Yellow. It illuminates steadily if any zone, alarm output or sounder output is disabled.
- ✧ **SUPERVISED:** Yellow. It illuminates steadily when any zone defined as supervisory is activated. (for future use)

- ✧ **IN TEST:** Yellow. It illuminates steadily when any zone is in test condition. (for future use)
- ✧ **POWER:** Green. It illuminates steadily when the FACP is powered up.
- ✧ **MAINS FAULT:** Yellow. It illuminates steadily when there is mains fault.
- ✧ **BATTERY FAULT:** Yellow. It illuminates steadily when there is battery fault.
- ✧ **CHARGER FAULT:** Yellow. It illuminates steadily when there is charger fault.
- ✧ **EARTH FAULT:** Yellow. It illuminates steadily when any cable of sounder output (voltage output), auxiliary power output or zone input connects with the enclosure of the panel.
- ✧ **SYSTEM FAULT:** Yellow. It illuminates steadily when the CPU is in fault condition or CPU communication is abnormal. The FACP enters safe state at the moment.
- ✧ **CONTROL ENABLE:** Green. It illuminates steadily when the control enable lock is pointed to ON.
- ✧ **DELAY MODE:** Yellow. It illuminates steadily when there is alarm output or sounder output in delayed condition. (for future use)
- ✧ **ALARM OUTPUT FLT/DIS:** Yellow. It flashes when alarm output is in fault condition, and it illuminates steadily when alarm output is disabled.
- ✧ **SOUNDER 1# FLT/DIS:** Yellow. It flashes when sounder 1# output is in fault condition, and it illuminates steadily when sounder 1# output is disabled.
- ✧ **SOUNDER 2# FLT/DIS:** Yellow. It flashes when sounder 2# output is in fault condition, and it illuminates steadily when sounder 2# output is disabled.
- ✧ **SOUNDER 3# FLT/DIS:** Yellow. It flashes when sounder 3# output is in fault condition, and it illuminates steadily when sounder 3# output is disabled.

1.3.2 Zone Status Indicators

- ✧ **ZONE FIRE LED (Z1~Z16):** Red. It flashes when a zone is in fire condition. The zone fire LED illuminates steadily when the zone defined as supervisory is activated.
- ✧ **ZONE FAULT LED (Z1~Z16):** Yellow. It flashes when the zone is in fault condition. And it illuminates steadily when the zone is disabled or in test.

1.3.3 Operating Indicators and Keys

- ✧ Keys with LEDs
 - **MUTE:** In access level I, pressing this key can mute fault sound. In access level II, pressing this key can mute fault sound, supervisory sound and fire alarm sound. When pressing this key, the mute LED illuminates yellow steadily.
 - **EVAC:** It is available in access level II. Pressing this key can activate all sounder outputs and the evac LED illuminates red steadily. This LED will turn off when all sounder outputs are closed.
 - **SILENCE/RESOUND:** It is available in access level II. In fire condition, pressing this key can silence or resound the sounders. When the sounders are silenced, the silence/resound LED illuminates yellow steadily.
 - **DISABLE/ENABLE:** It is available in access level II. Pressing this key can disable or enable an output or a zone and the LED illuminates green steadily.
 - **OUTPUT PROGRAM:** It is available in access level III. Pressing this key can set output

program and the LED illuminates green steadily. (for future use)

- **TEST:** It is available in access level II. Pressing this key can set test status and the LED illuminates green steadily. (for future use)

✧ Keys

- **RESET:** It is available in access level II for resetting the FACP.
- **DISABLE:** It is available in access level II. Pressing this key for 2s can disable all zones in fire condition.
- **UP:** It is available in access level II for scrolling up to choose.
- **DOWN:** It is available in access level II for scrolling down to choose.
- **CANCEL:** It is available in access level II for cancellation.
- **ENTER:** It is available in access level II for confirmation.

✧ Control Enable Lock

- **CONTROL ENABLE:** For access level control. If it's pointed to "OFF" position, the FACP is at the access level I. If it's pointed to "ON" position, the FACP is at the access level II.

1.4 Configuration and Functions

1.4.1 Internal Components

The internal construction of the FACP is shown in Fig. 1-2.

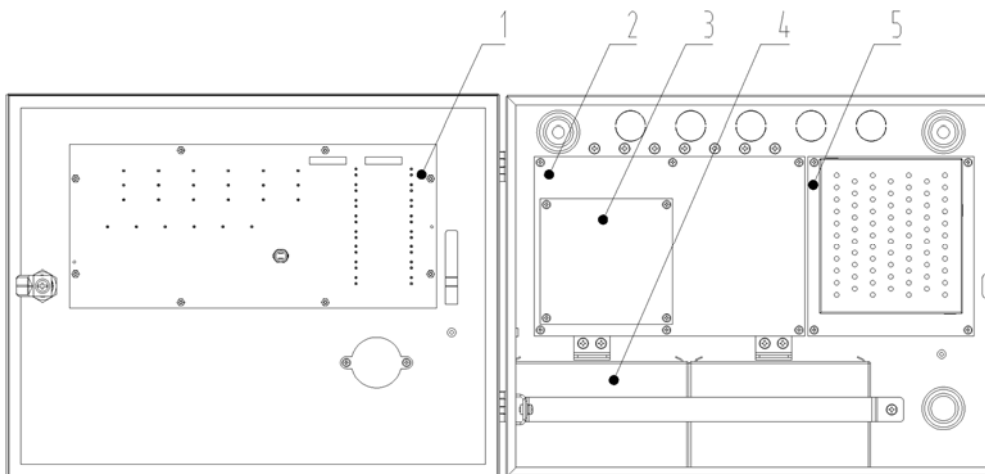

Fig. 1-2

- ① Display board ② Control board ③ Extension board ④ Batteries ⑤ Power board

1.4.2 Configuration and functions of TXC7016

- ✧ Power board: AC-DC switching power supply, providing DC24V for the FACP.
- ✧ Batteries: Standby power source for the FACP.
- ✧ Control board: For controlling power supply, charger, and all outputs such as fault/disable/supervisory relay output, alarm output, sounder outputs and monitoring the state of zone 1 to 8.
- ✧ Display board: For information display and key operation.
- ✧ Extension board: Providing detection input for zone 9 to 16.

- ✧ Relay board (optional): Controlling outputs of alarm relay and fault relay for zone 1 to 16.

1.4.3 Configuration and Functions of TXC7008

- ✧ Power board: AC-DC switching power supply, providing DC24V for the FACP.
- ✧ Batteries: Standby power source for the FACP.
- ✧ Control board: For controlling power supply, charger, and all outputs such as fault/disable/supervisory relay output, alarm output, sounder outputs and monitoring the state of zone 1 to 8.
- ✧ Display board: For information display and key operation.
- ✧ Relay board (optional): Controlling outputs of alarm relay and fault relay for zone 1 to 8.

1.4.4 Configuration and Functions of TXC7004

- ✧ Power board: AC-DC switching power supply, providing DC24V for the FACP.
- ✧ Batteries: Standby power source for the FACP.
- ✧ Control board: For controlling power supply, charger, and all outputs such as fault/disable/supervisory relay output, alarm output, sounder outputs and monitoring the state of zone 1 to 4.
- ✧ Display board: For information display and key operation.
- ✧ Relay board (optional): Controlling outputs of alarm relay and fault relay for zone 1 to 4.

1.4.5 Configuration and Functions of TXC7002

- ✧ Power board: AC-DC switching power supply, providing DC24V for the FACP.
- ✧ Batteries: Standby power source for the FACP.
- ✧ Control board: For controlling power supply, charger, and all outputs such as fault/disable/supervisory relay output, alarm output, sounder outputs and monitoring the state of zone 1 to 2.
- ✧ Display board: For information display and key operation.
- ✧ Relay board (optional): Controlling outputs of alarm relay and fault relay for zone 1 to 2.

1.5 Terminal Description

1.5.1 Power input terminals on Power Board and control board

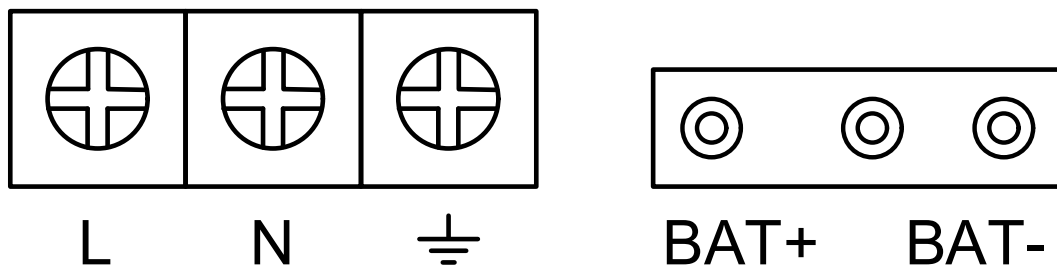

Fig. 1.3

- ✧ L, N, \perp : AC power input terminal.
- ✧ **BAT+**, **BAT-**: Battery input terminal.

1.5.2 Terminals on Control Board of TXC7002

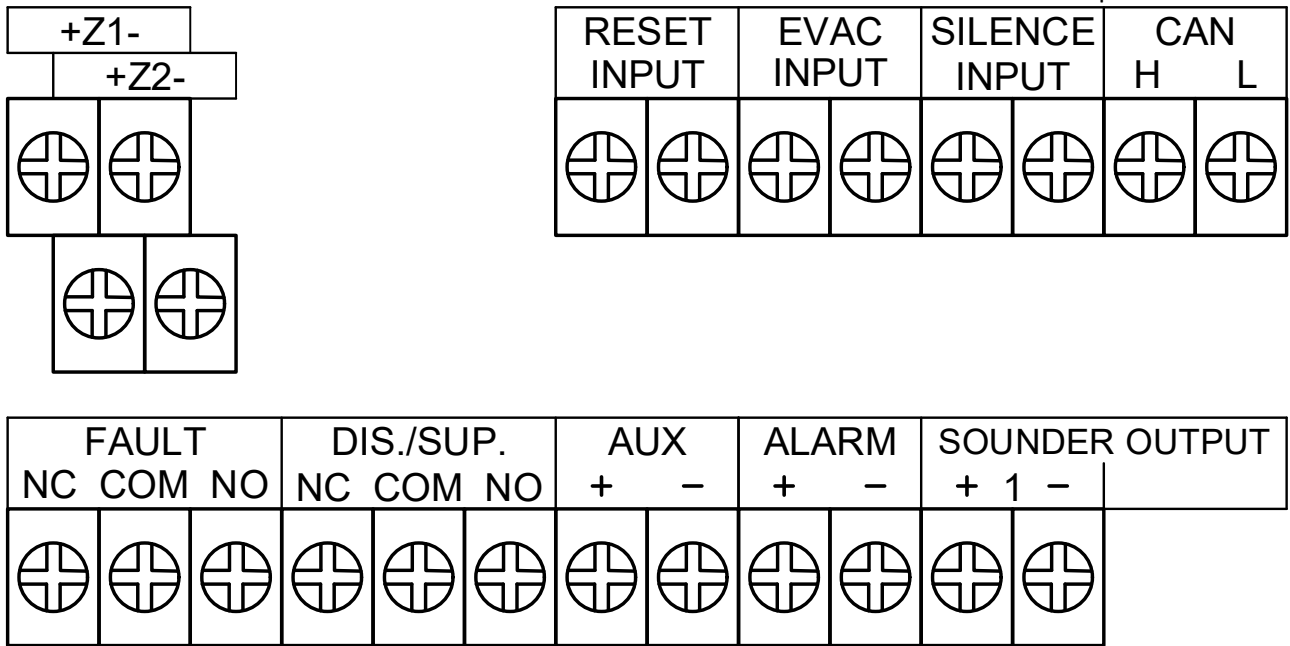

Fig. 1.4

- ✧ +Z1- ~ +Z2-: Zone 1 to 2 input terminals.
- ✧ **FAULT (NC, COM, NO)**: Fault output terminal.
- ✧ **DIS. / SUP. (NC, COM, NO)**: Disable/supervisory output terminal.
- ✧ **AUX (+, -)**: Auxiliary power output terminal.
- ✧ **ALARM (+, -)**: Alarm output terminal.
- ✧ **SOUNDER OUTPUT 1 (+, -)**: Sounder 1# output terminals.
- ✧ **RESET INPUT**: Reset input terminal (for future use).
- ✧ **EVAC INPUT**: EVAC input terminal (for future use).
- ✧ **SILENCE INPUT**: Silence input terminal (for future use).
- ✧ **CAN (H, L)**: CAN2.0B communication terminal (for future use).

1.5.3 Terminals on Control Board of TXC7004

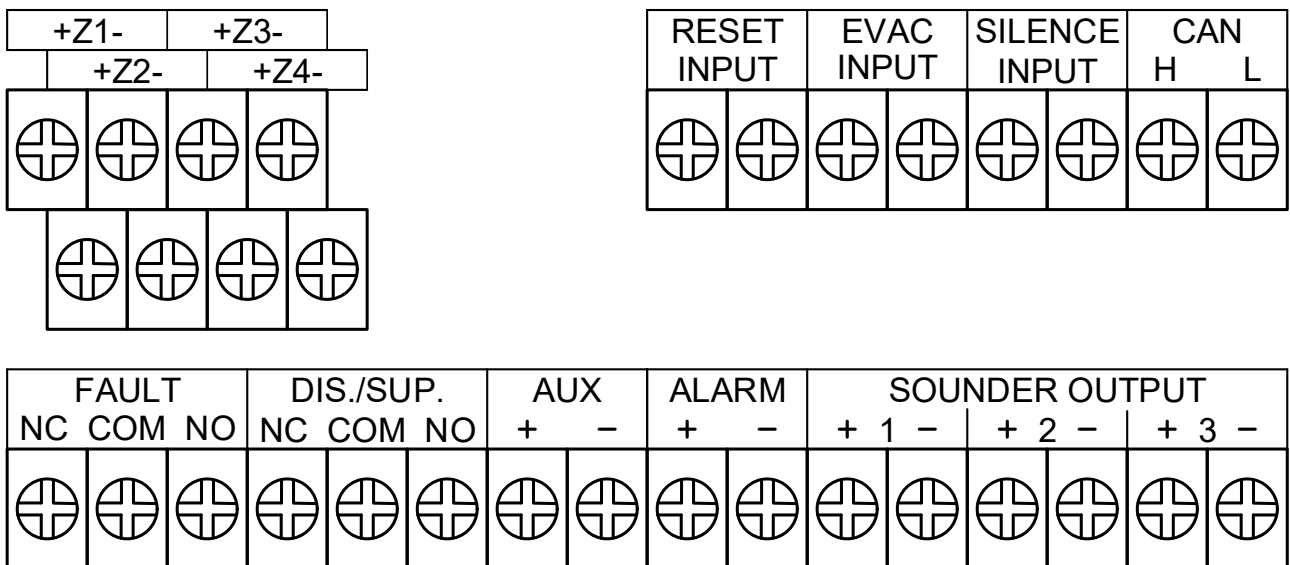

Fig. 1.5

- ✧ +Z1- ~ +Z4-: Zone 1 to 4 input terminals.
- ✧ **FAULT (NC, COM, NO)**: Fault output terminal.
- ✧ **DIS. / SUP. (NC, COM, NO)**: Disable/supervisory output terminal.
- ✧ **AUX (+, -)**: Auxiliary power output terminal.
- ✧ **ALARM (+, -)**: Alarm output terminal.
- ✧ **SOUNDER OUTPUT (1~3) (+, -)**: Sounder 1#~3# output terminals.
- ✧ **RESET INPUT**: Reset input terminal (for future use).
- ✧ **EVAC INPUT**: EVAC input terminal (for future use).
- ✧ **SILENCE INPUT**: Silence input terminal (for future use).
- ✧ **CAN (H, L)**: CAN2.0B communication terminal (for future use).

1.5.4 Terminals on Control Board of TXC7008 and TXC7016

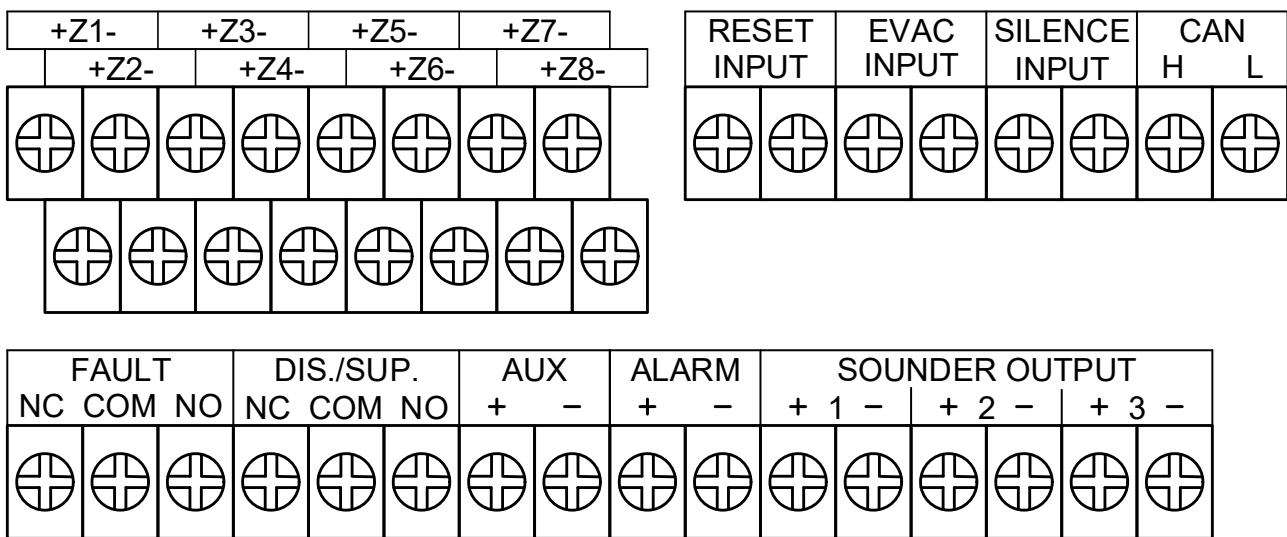

Fig. 1.6

- ✧ +Z1- ~ +Z8-: Zone 1 to 8 input terminals.
- ✧ **FAULT (NC, COM, NO)**: Fault output terminal.
- ✧ **DIS. / SUP. (NC, COM, NO)**: Disable/supervisory output terminal.
- ✧ **AUX (+, -)**: Auxiliary power output terminal.
- ✧ **ALARM (+, -)**: Alarm output terminal.
- ✧ **SOUNDER OUTPUT (1~3) (+, -)**: Sounder 1#~3# output terminals.
- ✧ **RESET INPUT**: Reset input terminal (for future use).
- ✧ **EVAC INPUT**: EVAC input terminal (for future use).
- ✧ **SILENCE INPUT**: Silence input terminal (for future use).
- ✧ **CAN (H, L)**: CAN2.0B communication terminal (for future use).

1.5.5 Terminals on Extension Board of TXC7016

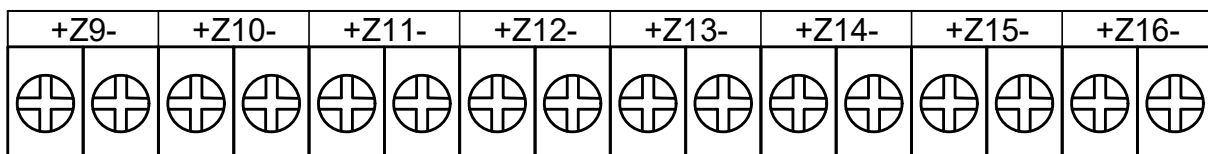

Fig. 1.7

- ✧ **+Z9- ~ +Z16-**: Zone 9 to 16 input terminals.

1.5.6 Terminals on Relay Board of TXC7016 (optional)

- ✧ **FAULT1~FAULT16**: Fault output terminals for zone 1 to 16.
- ✧ **ALARM1~ALARM16**: Alarm output terminals for zone 1 to 16.

1.5.7 Terminals on Relay Board of TXC7002/TXC7004/TXC7008 (optional)

- ✧ **FAULT1~FAULT8**: Fault output terminals for zone 1 to 8.
- ✧ **ALARM1~ALARM8**: Alarm output terminals for zone 1 to 8.

1.6 Overall Dimensions

The overall dimensions is 410mm×100mm×320mm (L×W×H).

2 Installation and Wiring

2.1 Installing the Cabinet

The FACP is wall-mounted in Fig. 2-1.

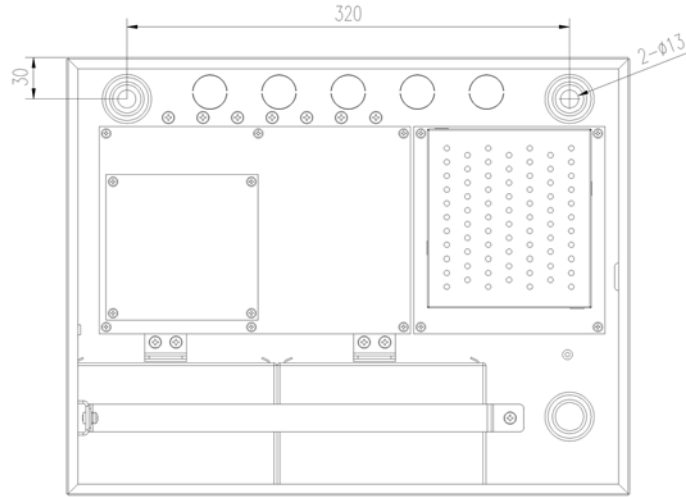

Fig. 2-1

Note: Cable connector should be installed in the knock-out hole to avoid cable abrasion and foreign objects.

2.2 Mains Connection

The FACP is powered by 120~240VAC, 50/60Hz. It's recommended to use 1.5mm² or above shield cable subject to local installation codes.

The incoming power cable ground (Green/Yellow) wire should be connected to the cabinet and be reliably grounded. Connect the neutral (Blue) wire to N of terminal P1 on power board and connect the Live (Brown) wire to L of terminal P1.

Note:

- *The power cables shall be fixed to the enclosure using a restraint clamp for strain relief.*
- *Do not power the system until the installation is completed.*

2.3 Battery Connection

Connect the batteries as in Fig. 2-2 and then to the battery terminal P2 on the control board.

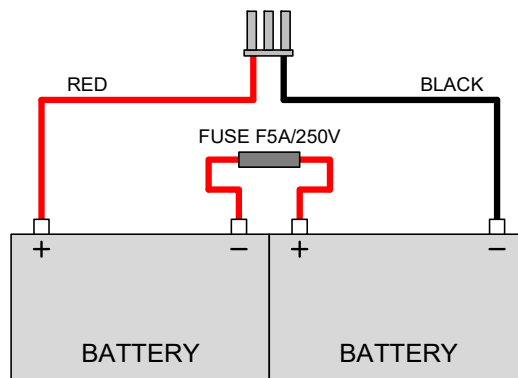

Fig. 2-2

Note:

- Refer to 5 Calculation of Batteries Capacity for the size of the required batteries.
- Do not make battery connections until the installation is completed.
- The fuse of the batteries may be broken if the polarity is connected incorrectly.

2.4 Zone Inputs Connection

Each zone can have maximum 15 fire detectors. The total number of detectors and manual call points in a zone should not exceed 32. Connect all manual call points in front of the detectors and put a 4.7kΩ resistor at the end of the loop, as shown in Fig. 2- 3.

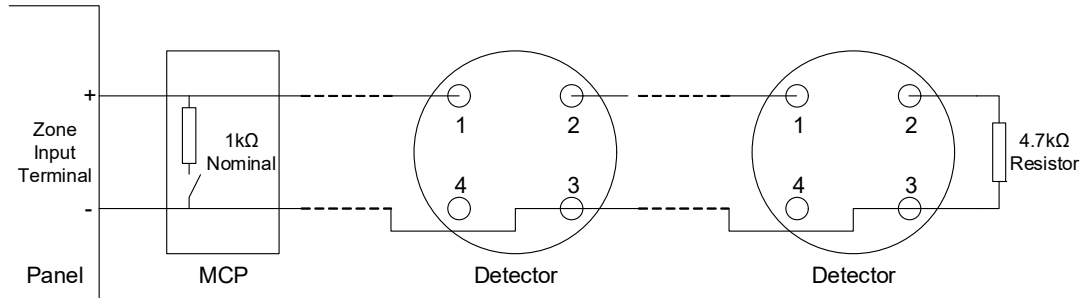

Fig. 2-3

2.5 Sounder Outputs Connection

All sounders shall be polarity-sensitive and be connected in correct polarity. A 4.7kΩ resistor shall be connected in parallel at the end of the loop. Fig. 2-4 shows the connection of sounder output.

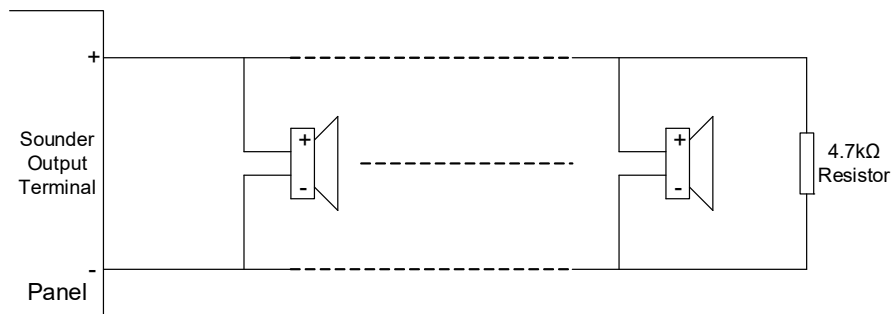

Fig. 2-4

3 System Setup

3.1 Setting Access Levels

The FACP provides three access levels:

- ✧ Level I, for anybody to mute the buzzer for fault.
- ✧ Level II, for person on duty to disable, test, reset the panel, mute the buzzer, silence/resound the sounder outputs, evacuate the building and so on.
- ✧ Level III, for special service engineer to turn on or off the FACP and program output modes.

Note: The function of the FACP will be altered if you change any position on switch of SW1 and SW2 that are defaulted OFF. Therefore, the FACP will be set after the manual is read and understood.

3.1.1 Setting Access Level I

Turning CONTROL ENABLE lock to OFF shown as in Fig. 3-1, and switch the "1" (LEVEL 3) of SW1 on control board to off position as shown in Fig. 3-3, the FACP is set to access level I.

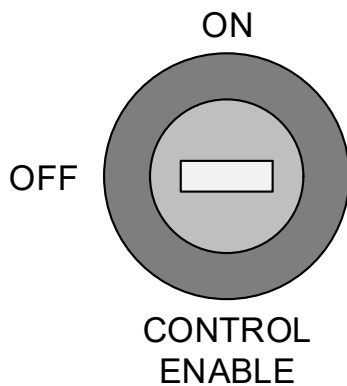

Fig. 3-1

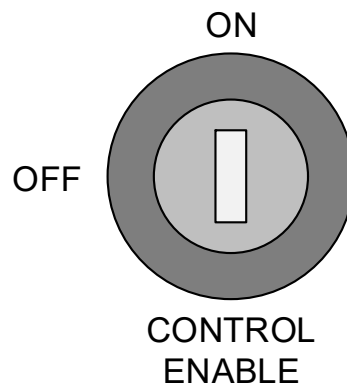

Fig. 3-2

3.1.2 Setting Access Level II

Turning CONTROL ENABLE lock to ON shown as in Fig. 3-2, and switch the "1" (LEVEL 3) of SW1 on control board to off position as shown in Fig. 3-3, the FACP is set to access level II.

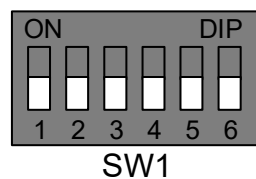

Fig. 3-3

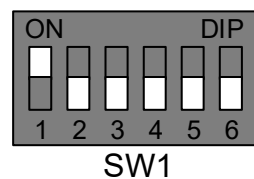

Fig. 3-4

3.1.3 Setting Access Level III

If the "1" (LEVEL 3) of SW1 on control board is set to ON position as shown in Fig. 3-4, whichever position the Control Enable lock is, the FACP is set to access level III.

3.2 Setting Alarm/ Sounder 1# Output

Alarm output and sounder 1# output can be set through pins for three output modes: voltage output, normally open contact output and normally closed contact output. The default setting for alarm output and sounder 1# output is voltage output. Alarm output and sounder 1# output is set as shown in Table 3-1.

Table 3-1

Output	Normally closed contact	Normally open contact	Voltage output
	Jumpers	Jumpers	Jumpers
Alarm output	X3: 1 & 2, 3 & 4	X3: 1 & 2, 4 & 5	X3: 2 & 3, 5 & 6
Sounder 1# output	X4: 1 & 2, 3 & 4	X4: 1 & 2, 4 & 5	X4: 2 & 3, 5 & 6

3.3 Setting Disablement Function

3.3.1 Use of Disablement Function

In case there is any fault with a zone or an alarm/sounder output, it can be disabled so that it does not affect normal operation of other zones. After the fault is removed, the disabled zones or outputs can be enabled again.

There are two ways for using disablement function: basic steps and quick disablement.

Note: Disable status setting can be saved even if the FACP is powered off.

3.3.2 Basic Disablement Function

1. Enter access level II.
2. Pressing *DISABLE/ENABLE* key, the *DISABLE/ENABLE* LED illuminates steadily and the *ZONE FAULT LED* of zone 1 starts flashing to show zone 1 is selected for disablement setup. The *DISABLE* LED illuminates steadily when any disablement event occurs. The *FAULT* LED will indicate according to the FACP fault condition. Other indicators, except for the mentioned LEDs above, will be turned off.
3. Pressing *UP* or *DOWN* key can switch among zone 1 to 16, alarm output and sounder outputs.
4. The corresponding fault LED will flash when the selected zone or output is not to be disabled and illuminate when the selected zone or output is to be disabled.
5. Pressing *ENTER* key can change the disable/enable state of zones, alarm output or sounder outputs and the FACP will give 1s sound indication.
6. Pressing *CANCEL* key exits disablement setting status and the *DISABLE/ENABLE* LED will be turned off.
7. Exit access level II.

3.3.3 Quick Disablement Function

This *DISABLE* key can be used for disabling all zones in fire condition. The following steps show how to operate the *DISABLE* key.

1. Enter access level II.
2. Pressing *DISABLE* key for 2s, all zones in fire condition will be disabled, *DISABLE* LED and the *ZONE FAULT LED* of zones will illuminate steadily.
3. Exit access level II.

3.4 Setting Test Mode (For future use)

3.4.1 Use of Test Mode

Test mode is for testing if a zone works normally. In this mode, if a zone can generate a fire alarm signal when it's manually put into fire condition, it shows this zone works properly. Alarm Output will not be activated, and sounder outputs can be programmed to either output for 15s or not.

Note: Test mode cannot be saved if the FACP is powered off.

3.4.2 Operation Steps

- 1 Enter access Level II.
- 2 Pressing *TEST* key, *TEST* LED illuminates steadily. The *ZONE FAULT LED* of zone 1 starts flashing, showing the FACP is in test mode and then zone 1 is selected. The *FAULT* LED will indicate according to the FACP fault condition. Other indicators, except for the mentioned LEDs above, will be turned off.
- 3 Pressing *UP* or *DOWN* key can switch among zone 1 to 16.
- 4 The *ZONE FAULT LED* will flash when the selected zone is not in test mode and illuminate when the selected zone is in test mode.
- 5 Pressing *ENTER* can change the zone is defined as test zone or not and the FACP will give 1s sound indication.
- 6 Pressing *CANCEL* exits test mode setting status and the *TEST* LED will be turned off.
- 7 Exit access Level II.

3.5 Programming Output Mode (For future use)

All output settings have to be done in access level III. So before setting the outputs, please first mode the FACP to enter access level III according to the instructions in Section 3.1.3.

3.5.1 Setting "With Manual Call Point"

If a zone is set "With Manual Call Point", any fire alarm coming from that zone (either from a detector or a manual call point), the FACP will immediately alarm and activate all sounders associated to that zone and the alarm output regardless of any delay setting. Basic steps are shown below.

- 1 Enter access level III.
- 2 Set ZONE MCP CFG of SW1 on control board to ON position.
- 3 Pressing OUTPUT PROGRAM key, the OUTPUT PROGRAM LED illuminates steadily and the ZONE FAULT LED of zone 1 flashes to show zone 1 is to be selected for "With Manual Call Point" setup. And DELAY MODE LED flashes. The Fault LED will indicate according to the FACP fault condition. Other indicators, except for the mentioned LEDs above, will be turned off.
- 4 Pressing UP or DOWN key can switch among zone 1 to 16.
- 5 The ZONE FAULT LED will flash when the zone is set "With Manual Call Point" and illuminate when the zone is not set "With Manual Call Point".
- 6 Pressing ENTER key can change the state whether the zone is defined as "With Manual Call Point" or not and the FACP will give 1s sound indication.
- 7 Pressing CANCEL key exits the programming mode and the OUTPUT PROGRAM LED will be turned off.
- 8 Set ZONE MCP CFG of SW1 on control board to OFF position.
- 9 Exit access level III.

Note: If one of the outputs (sounder outputs or alarm output) is programmed with delay, then there should be at least one zone set as "With Manual Call Point" to ensure the delay could be overrode for immediate output.

3.5.2 Setting Associated Sounder Outputs of a Zone

Output types, sounder patterns and delay time of sounder outputs can be set separately for each

zone. Four output modes are shown in Table 3-2.

Table 3-2

Type	Description	<i>DISABLE/ENABLE</i> LED	<i>TEST</i> LED
1	No output	OFF	OFF
2	Output after alarm output activated	OFF	ON
3	Delay output	ON	OFF
4	Immediate output	ON	ON

Two sounder patterns are shown in Table 3-3.

Table 3-3

Sounder Patterns	OUTPUT DELAY of SW1
Pulse Output (3s ON, 1s OFF)	ON
Continuous Output	OFF

Delay can be calculated as shown in Table 3-4.

Table 3-4

Delay Time (s)	DELAY TIME 1~2 of SW1	
	Pin 5	Pin 6
0	OFF	OFF
30	ON	OFF
60	OFF	ON
120	ON	ON

Operation steps of zone association output setting are shown below.

- 1 Enter access level III.
- 2 Set the *SOUNDER MODE* of SW1 on control board to ON position.
- 3 Pressing *OUTPUT PROGRAM* key, *OUTPUT PROGRAM* LED illuminates steadily and the *ZONE FAULT LED* of zone 1 flashes to show zone 1 is to be selected for setting associated sounder outputs. The *FAULT LED* will indicate according to the FACP fault condition. Other indicators, except for the mentioned LEDs above, will be turned off.
- 4 Pressing *UP* or *DOWN* key can switch among zone 1 to 16.
- 5 Press *OUTPUT PROGRAM* key again to set up its associated sounder outputs. The *SOUNDER 1# FLT/DIS* LED flashes, showing sounder output 1 has been selected for setup.
- 6 Pressing *UP* or *DOWN* key will shift from sounder output 1 to 3.
- 7 Pressing *DISABLE/ENABLE* or *TEST* key can respectively switch on or off their indicator. The *DISABLE/ENABLE* LED and *TEST* LED are used for setting up and indicating the output logic of the selected sounder output, as shown in Table 3-2.
- 8 Set the *OUTPUT DELAY* of SW1 to ON or OFF can change the sound pattern of the selected sounder output, as shown in Table 3-3.
- 9 *DELAY TIME 1* and *DELAY TIME 2* of SW1 are used for setting the delay time of the selected sounder output, as shown in Table 3-4.
- 10 Pressing *ENTER* key saves the current settings and the FACP will sound for 1s to indicate the successful setup. Repeat step 6 to 9 to set another sounder output for this zone.

- 11 Press *CANCEL* key to exit setup for this zone without saving and return to zone selection step. Repeat step 4 to 10 to select another zone for setup.
- 12 At zone selection step, pressing *CANCEL* key again will exit programming mode. And *OUTPUT PROGRAM* LED will be turned off.
- 13 Set the *SOUNDER MODE* of SW1 on control board to OFF position.
- 14 Exit access level III.

3.5.3 Setting Delay Time of Alarm Output

Delay time of alarm output can be set through the following steps.

- 1 Enter access level III.
- 2 Set the *OUTPUT DELAY* of SW1 on control board to ON position.
- 3 Pressing *OUTPUT PROGRAM* key, the *OUTPUT PROGRAM* LED illuminates steadily and *ALARM OUTPUT FLT/DIS* LED flashes to show the FACP enters alarm output delay time setup. The *FAULT* LED will indicate according to the FACP fault condition. Other indicators, except for the mentioned LEDs above, will be turned off.
- 4 *DELAY TIME 1* and *DELAY TIME 2* of SW1 are used for setting the delay time of alarm output, as shown in Table 3-4.
- 5 Pressing *ENTER* key saves the current setting. The FACP will sound for 1s to indicate the successful setup.
- 6 Pressing *CANCEL* key will exit alarm output delay time setup and the *OUTPUT PROGRAM* LED will be turned off.
- 7 Set the *OUTPUT DELAY* of SW1 on control board to OFF position.
- 8 Exit access level III.

3.6 Setting Supervisory (For future use)

3.6.1 Use of Supervisory Function

Zones can be defined as supervisory for monitoring field device status.

Note: Supervisory setting can be saved even if the FACP is powered off.

3.6.2 Operation Basic Steps

- 1 Enter access level III.
- 2 Set the *ZONE SUP. CFG* of SW2 on control board to ON position.
- 3 Pressing *OUTPUT PROGRAM* key, *OUTPUT PROGRAM* LED illuminates steadily and the *ZONE FAULT LED* of zone 1 starts flashing to show zone 1 is to be selected for supervisory setup. And *SUPERVISED* LED flashes. The *FAULT* LED will indicate according to the FACP fault condition. Other indicators, except for the mentioned LEDs above, will be turned off.
- 4 Pressing *UP* or *DOWN* key can switch among zone 1 to 16.
- 5 The *ZONE FAULT LED* will flash when the selected zone is not defined as supervised zone and illuminate when the selected zone is defined as supervised zone.
- 6 Pressing *ENTER* key can change whether the zone is defined as supervised or not and the FACP will give 1s sound indication.
- 7 Pressing *CANCEL* key exits supervisory setting status and *OUTPUT PROGRAM* LED turns off.
- 8 Set the *ZONE SUP. CFG* of SW2 on control board to OFF position.
- 9 Exit access level III.

3.7 Setting Auxiliary Functions (For future use)

- ✧ DISABLE/SUPERVISED OUTPUT MODE: When the *RELAY DIS./SUP.* of SW2 is set to OFF position, the disable/supervised relay output is set for disable output; otherwise, this output is set for supervised output.
- ✧ RESOUND MODE: When the *RESOUND MODE* of SW2 is set to ON position, resound mode is turned on. When there is fire alarm from a zone, the sounder outputs associated to this zone will be started. Pressing *SILENCE/RESOUND ALARM* key and these sounder outputs can be silenced; if there is an alarm signal from another zone at this moment, the silenced sounder outputs that are not associated to this new alarm zone will resound. If resound mode is turned off, the silenced sounder outputs not associated to this new alarm zone will remain silenced.
- ✧ SILENCE RESET MODE: When the *SILENCE RESET* of SW2 is set to ON position, silence-reset mode is turned on. When there is fire alarm from a zone and its associated sounder outputs are started, the FACP will not be reset until the sounder outputs are silenced.
- ✧ SILENCE DELAY MODE: When the *SILENCE DELAY* of SW2 is set to ON position, silence-delay mode is turned on. When there is fire alarm from a zone and its associated sounder outputs are started, the FACP has to stay in fire condition for 3 minutes before the sounder outputs could be silenced.
- ✧ TEST SOUNDER MODE: When the *TEST SOUNDER* of SW2 is set to ON position, test zone output mode is turned on. When a zone is in test mode and there is an alarm signal coming from the zone, the sounder outputs associated to the zone will be automatically activated for 15s.

3.8 Ground Fault Detection

Shorting pin 1 and pin 2 of X2 with a jumper, the FACP will be able to detect the earth fault. Otherwise, the earth fault can't be detected.

3.9 Setting Auxiliary Power

Shorting *AUX* and *DC24V* of X1 with a jumper, the *AUX* output will steady output. If shorting *AUX* and *Z_24V* of X1 with a jumper, the *AUX* output will stop output for about 10 seconds when the FACP is reset.

3.10 Restore Default Settings (For future use)

The basic features of the default settings are as follows:

- ✧ Every zone is set "With Manual Call Point".
- ✧ When there is fire alarm from any zone, all sounder outputs will be activated, and these outputs will be continuous and not be delayed.
- ✧ The alarm output is not set with delay time.
- ✧ All zones, alarm output and sounder outputs are not disabled.

A quick way to restore default settings as follows.

- 1 Enter access level III.
- 2 Pressing *OUTPUT PROGRAM* key for at least 2 seconds, the FACP gives 1s sound indication and it is restored default settings.
- 3 Exit access level III.

4 Operation Instructions

4.1 Working State Description

4.1.1 Zones State

- ✧ Normal: If a zone is in normal condition, the *ZONE FIRE LED* and *ZONE FAULT LED* should be off.
- ✧ Fire: If there is a zone in fire condition, *FIRE ALARM LED* illuminates steadily and the *ZONE FIRE LED flashes*.
- ✧ Supervisory: If there is a zone in supervisory condition, *SUPERVISED LED* and the *ZONE FIRE LED* illuminate steadily.
- ✧ Fault: If there is a zone in fault condition, *FAULT LED* illuminates steadily and the *ZONE FAULT LED flashes*.
- ✧ Disabled: If there is a zone in disabled condition, *DISABLE LED* and the *ZONE FAULT LED* illuminate steadily.

4.1.2 Alarm Output State

- ✧ Normal: If the alarm output is in normal condition, *ALARM OUTPUT LED* and *ALARM OUTPUT FLT/DIS LED* should be off.
- ✧ Action: If the alarm output is activated, *ALARM OUTPUT LED* illuminates steadily.
- ✧ Fault: If the alarm output is in fault condition, *FAULT LED* illuminates steadily and *ALARM OUTPUT FLT/DIS LED* flashes.
- ✧ Disabled: If the alarm output is disabled, *DISABLE LED* and *ALARM OUTPUT FLT/DIS LED* illuminate steadily.

4.1.3 Sounder Outputs State

- ✧ Normal: If a sounder output is in normal condition, *SOUNDER X# FLT/DIS LED* should be off.
- ✧ Fault: If there is a sounder output in fault condition, *FAULT LED* illuminates steadily and *SOUNDER X# FLT/DIS LED* flashes.
- ✧ Disabled: If there is a sounder output in disabled condition, *DISABLE LED* and *SOUNDER X# FLT/DIS LED* illuminate steadily.

4.1.4 Safe State

When there is fault with any CPU that makes the FACP unable to work properly or changes system data, the FACP will enter safe state.

- ✧ *FAULT* and *SYSTEM FAULT LED* illuminate.
- ✧ The buzzer sounds continuously.
- ✧ The keypad cannot be operated.
- ✧ The FACP cannot monitor fire.
- ✧ Fault output is activated.
- ✧ Other outputs remain the states before the FACP enters safe state.
- ✧ Other indicators remain the states before the FACP enters safe state.

Note: Safe state can only be cleared by re-powering the FACP.

4.1.5 Description of the Buzzer

The buzzer of the FACP sounds by priority coming from high to low as follows: safe state, fire alarm, supervisory, fault and normal. The sound patterns of the buzzer are:

- ✧ Safe state, sounds steadily.

- ✧ Fire alarm, 0.5s on, 0.5s off.
- ✧ Supervisory, 1s on, 1s off.
- ✧ Fault, 2s on, 2s off.
- ✧ Normal, no sound.

4.1.6 Others

- ✧ Access levels are downwards applicable. A higher level enables access at levels lower than it.
- ✧ If there is no key pressed for over 3 minutes, all previous operation will be canceled and the FACP would return to normal standby state.
- ✧ RESET input, EVAC input and SILENCE input are contact input type. If an input is shorted for 2s, the FACP will operate correspondingly regardless of access levels.
- ✧ Alarm output and sounder outputs will not be activated if they are disabled or in fault.

4.2 Muting of Buzzer

In access level I, pressing MUTE key can mute fault sound, and in access level II, pressing it can mute fire sound and supervisory sound.

4.3 Silencing the Sounder Outputs

In fire condition, pressing *SILENCE/RESOUND ALARM* key at access level II will silence the sounder outputs and pressing it again will make them resound.

4.4 Evacuation

In access level II, pressing *EVAC* key, all sounder outputs will be activated continuously. Pressing *EVAC* key again, all sounder outputs will be stopped.

4.5 Self-test and Reset

The FACP will start self-test on power-up. In access level II, pressing *RESET* key can clear all audio and visual indication and check all indicators and the buzzer. All indicators illuminate and the buzzer sounds. After self-test, the panel returns to normal condition.

5 Calculation of Batteries Capacity

The formula for calculating batteries capacity is as follows:

$$\text{Batteries Capacity (Ah)} = (I_{Q_{\max}} + I_{Q_{\text{out}}}) \times T_1 + (I_{Q_{\min}} + I_{L_{\max}} + I_{F_{\text{out}}}) \times T_2$$

In which,

$I_{Q_{\max}}$ is the maximum standby current of the FACP in full load, which is 0.12A (calculated based on 16 zones).

$I_{Q_{\text{out}}}$ is the auxiliary output current in standby condition, which is 0.02A.

$I_{Q_{\min}}$ is the FACP circuit consumption in fire condition, which is 0.1A.

$I_{L_{\max}}$ is the loop maximum current allowed for 16 detection zones, which is 0.4A.

$I_{F_{\text{out}}}$ is the output current in alarm condition, which is 1.7A (0.3A for alarm output, 0.9A for 3 sounder outputs and 0.5A for the auxiliary output).

T_1 is the time for the batteries to work in monitoring status which shall be 24 hours by EN 54-4 standard.

T_2 is the time for the batteries to work in alarm status which shall be 30 minutes by EN 54-4 standard. From the above, we can get the maximum battery capacity is 4.46Ah, so that we recommended a 7AH battery to be used for the system. And as the above calculations are based on the 16-zone TXC7016, they are also applicable to TXC7002/TXC7004/TXC7008.

6 Installation Precautions

Adherence to the following will aid in problem-free installation with long-term reliability:

- ✧ Do not attempt to install, service, or operate this unit until this manual is read and understood.
- ✧ This equipment must be installed in accordance with these instructions and the appropriate national, regional and local regulations specific to the country and location of the installation. Consult with the appropriate Authority Having Jurisdiction (AHJ) for confirmation of the requirements.
- ✧ The FACP shall only be installed and serviced by specially trained engineers.
- ✧ Disconnect all sources of power before servicing. Control unit may be damaged by removing and/or inserting cards, modules, or interconnecting cables while the unit is energized.
- ✧ Remove all electronic assemblies prior to any drilling, filing, reaming, or punching of the enclosure. When possible, make all cable entries from the sides or rear. Before making modifications, verify that they will not interfere with batteries and printed circuit board location.

7 Servicing

The FACP shall be serviced by specially trained engineers. Please disconnect power before servicing.

7.1 Replacing the Batteries

- ✧ Batteries type: Sealed lead-acid battery
- ✧ Recommend period for replacement: 5 years (25°C)
- ✧ Recommended manufacturer and model: Yuasa NP7-12
- ✧ Disposal of used batteries: Please properly dispose the used batteries according to your local

✧ rules and regulations.

WARNING:

RISK OF EXPLOSION IF BATTERIES ARE REPLACED BY AN INCORRECT TYPE!

7.2 Replacing the Fuse

There is a fuse in battery cable and the type of the fuse is 5A/250VAC, fast, low breaking capacity glass tube fuse. Follow the steps below to replace a fuse:

- ✧ Unfasten the fuse holder in the battery connection to find 5A fuse.
- ✧ Replace the 5A fuse.
- ✧ Fasten the fuse holder.

Note: Please disconnect power before replacing the fuse.

TANDA DEVELOPMENT PTE. LTD.

438A Alexandra Road, #02-11 Alexandra Technopark, 119967 Singapore

+65 69141680 Info@tandasystem.com

www.tandasystem.com